

La Farga



Innovative
sustainable
copper

Catalogue

CONDUCTORS FOR RAILWAY ELECTRIFICATION

Electrifying the transport that moves us with
the most sustainable copper solutions









WE ARE YOUR PARTNER

Innovation and efficiency to contribute to a more sustainable transport

We are a family-owned industrial company with more than 215 years of activity, specialising in the manufacture of semi-processed copper products. **A world leader in copper recycling technology and processes**, with our first patent registered in 1986.

Copper is essential for the future of our society. The essential mineral, as it ensures maximum conductivity and exponentially reduces greenhouse gas emissions, contributing to the decarbonisation of our society.

Our innovative spirit and experience in the sector positions us as a world leader in copper technology and processing, both from cathode

and directly from recycled copper. Our facilities cover the entire manufacturing process, from copper smelting to the conductor.

This makes us **the best partner to produce all kinds of high-performance copper and copper alloy solutions** for railway applications.

We have an extensive portfolio of conductors for railway electrification for all types of infrastructures: conventional lines, high-speed lines, metros and trams.

Our production process is subject to exhaustive and meticulous quality control, from the smelting of the copper to the final product. The

entire organisation is geared towards ensuring maximum quality, complying with customer requirements and supervising each stage of the process, with the aim of achieving total customer satisfaction.

Present in more than 74 countries, it is thanks to our globalisation capacity that we can continue to promote the circular model in the international railway sector, offering circularity of copper materials at the end of their useful life.

We guarantee the highest quality standards and compliance with international specifications

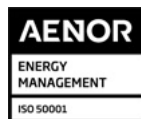

OUR TEAM, LA FARGA'S DRIVING FORCE

At La Farga we are fully confident in our team's ability to transform reality and be agents of change generating value. They are the driving force that drives the company, positioning us as leaders in the sector thanks to their talent and commitment.

Collaboration and teamwork have been key to addressing opportunities and challenges for more than 215 years. What we do is as important as how we do it for La Farga.

We are a company with a purpose, which makes us unique. Committed to people and our values. Our positioning and conviction makes us stand out in the metallurgical sector as a company active in generating shared value.

We work with a long-term vision to ensure the viability and sustainability of the company.



WE CONTRIBUTE TO THE DECARBONISATION OF THE PLANET AND ECONOMY

At La Farga we are aware of the environmental impact of industry, but it is also true that our activity is essential for human development and the energy transition.

One of our values is innovation, and from the very beginning we have invested and worked to put innovation at the service of sustainability.

We incorporate technologies that enable us to reduce emissions throughout the value chain and work more efficiently.

2023 goal - to reduce GHG emissions into the atmosphere by 55% (compared to 2017)

2050 goal - to achieve NetZero goals with minimal greenhouse gas emissions offsets.



SOLUTIONS WITH THE LOWEST IMPACT

Contributing to global decarbonisation goals

OUR BRANDS



La Farga, our legacy.

Our more than 215 years' experience has made us a recognised brand, a sign of quality with offices across almost all continents.

LA FARGA's solutions stand out both for our own manufactured products (wire rod, wire drawing, tubes, welding wires, railway and special cables, etc.), as well as for our knowledge and new copper processing technologies.

What we are today is the result of the strictest quality and efficiency processes, from raw materials and processing to customer service.



Genius, 100% recycled and 100% recyclable copper with the lowest carbon footprint.

We offer the most sustainable copper solutions with the lowest impact, directly producing 100% recycled copper tubes with the lowest carbon footprint on the market and contributing to the most efficient use of natural resources.

We ensure product traceability. This evolution highlights the objective of offering a unique value proposition, thanks to the company's innovation and excellence.

We are proud to be the first company in the copper sector that has been awarded certification for its wire rod product with an Environmental Product Declaration (EDP), endorsing the GENIUS product as the most sustainable on the market.

We continue working to certify the traceability of all our solutions and offer our clients the lowest environmental impact.

WE PROMOTE THE CIRCULAR ECONOMY IN RAIL TRANSPORT

Our circularity model is interlinked with sustainability, promoting the **efficient use of natural resources and process efficiency, extending the useful life of our solutions and maximising the reuse of copper when it has reached the end of its useful life** or of copper left over from the industrial process.

We have years of experience working on circular

models with our customers as well as providing solutions for eco-design and decarbonisation throughout the chain.

We are actively involved in influential groups in society with a focus on promoting circularity.

We promote other industries to get involved in the development of the circular economy, in the decarbonisation of activity and in reducing environmental impact.





Conductors for railway electrification / La Farga



Raw Material
Cu

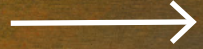

Manufacturing
process



La Farga
solutions



Final product
manufacturing/
sales and distribution



Use and
consumption



End of the
useful life



Copper
recycling



A WORLD LEADER IN RAILWAY PROJECTS

Present all over the world

● PASSENGER AND FREIGHT LINES

Acharnes - Tirhorea Greece
Athens - Tithorea Greece
Bourg - Bellegarde France
Casablanca - Kentira Morocco
Casablanca - Rabat Morocco
Cata - Apata Romania
Mediterranean Corridor Spain
Covilha - Guarda Portugal
Crossrail England
Dar es Salaam - Morogoro Tanzania
Delhi - Ghaziabad - Meerut India (CL+)
Diva - Koper Slovenia
Eastern EDFC India
Railway electrification for mines United States
Enlace - Manacor Spain
Heerhugowaard The Netherlands
Hernani - Irún Spain
Kayas - Centikaya Turkey
Kiato - Rododafni Greece
Korail South Korea
Kozzika - Cairo Egypt
Minho Line: Porto - Valença Portugal
Northern Line: Ovar-Gaia Portugal
Follo Line
Lisboa - Evora Portugal
Lisboa - Oporto Portugal
Official Supplier for NRIC Projects, Bulgaria
Official Supplier for RFI Projects, Italy
Official Supplier for SNCF Projects, France
Marcilla - Alar del Rey Spain
Marmaray Turkey
Modernisation of Latvian lines Latvia
Modernisation of Israeli lines Israel
Morogoro - Makutupora Tanzania (CL+)
Mwanza - Isaka Tanzania (CL+)

Plodiv - Burgas Bulgaria
Official Project Supplier for ADIF Spain
Septemvri - Plovdiv Bulgaria
Settat - Marrakesh Morocco
Sighisoara - Brasov Romania
Stuttgart S21 Germany
Greater Casablanca Triangle Morocco
Regional Express Train (TER) Dakar
Tren Maya Mexico (CL+)
Transtu Tunisia
Trønder - Meråker Norway
Xianxiang - Rizhao China

● TRAMWAY

Auxum Milan Italy
Barquisimeto Venezuela
Bergen Norway
Caen France
Constantina Algeria
Dublin Ireland
Dubai United Arab Emirates
Strasbourg France
Florence Italy
Luxembourg Luxembourg
Lusail Qatar
Melbourne Australia
Nottingham England
Oran Algeria
Rabat Morocco
Rennes France
Riad Saudi Arabia
Toulouse France
Sydney Australia
Valenciennes France

Certified by leading
Infrastructure Managers



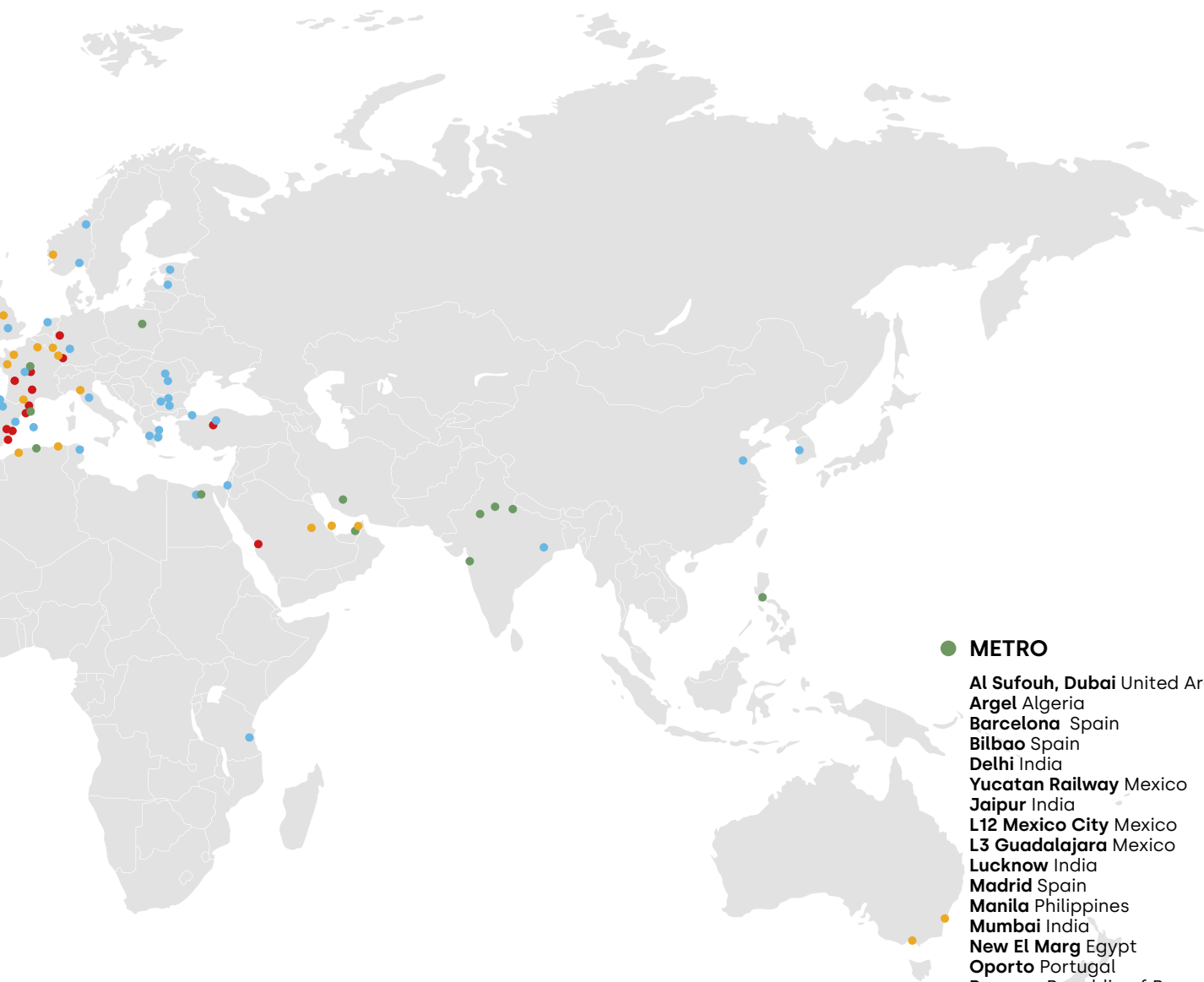

● **METRO**

- Al Sufouh, Dubai** United Arab Emirates
- Argel** Algeria
- Barcelona** Spain
- Bilbao** Spain
- Delhi** India
- Yucatan Railway** Mexico
- Jaipur** India
- L12 Mexico City** Mexico
- L3 Guadalajara** Mexico
- Lucknow** India
- Madrid** Spain
- Manila** Philippines
- Mumbai** India
- New El Marg** Egypt
- Oporto** Portugal
- Panama** Republic of Panama
- Paris** France
- Quito** Ecuador
- Montreal REM** Canada
- Santo Domingo** Dominican Republic
- Shiraz** Iran
- Varsovia** Poland

● **HIGH-SPEED LINES**

- Alcázar - Manzanares** Spain
- Ankara - Istanbul** Turkey
- Atocha - Chamartín** Spain
- Barcelona - Figueres** Spain
- Barcelona - French border** Spain
- Mecca - Medina** Saudi Arabia
- East Metz HSL - Strasbourg** France
- Morocco HSL** Morocco
- Madrid - Valencia** Spain
- Medina del Campo - Salamanca** Spain
- Monforte - Murcia** Spain
- Rin-Ródano** France
- Santiago - Ourense** Spain
- Sea Bourg - Bordeaux (Southern Europe Atlantic HSL)** France
- Seville - Cadiz** Spain
- Torrente - Xátiva** Spain
- Valencia - Alicante** Spain
- Vigo - A Coruña** Spain
- Wendlingen - Ulm** Germany







Conductors for railway electrification / **Solutions**

CATENARY SOLUTIONS



CATENARY SOLUTIONS

The complete range of catenary solutions

Our solutions for railway electrification are the result of innovation and technology developed by La Farga, achieving higher performance and wear resistance than conventional catenary.

Our complete portfolio of copper and copper alloy solutions with tin, silver and magnesium are the best solutions for **high-speed lines, passenger and freight lines, metros and tramways**.

In addition, we also have a manual available with recommendations for installing and handling our products in railway installations, as well as offering our technical team, with extensive experience, to advise our clients.

We manufacture the full range of copper solutions that the railway market requires:

- **Contact wire**
- **Rigid cables**
 - Messenger wire
 - Feeder
 - Connection cables
- **Flexible cables**
 - Dropper
 - Connection cables

Range of solutions available for both brands:

- 1 Contact wire

RIGID CABLES

- 2 Messenger wire
- 3 Feeder
- 5 Connection cables

FLEXIBLE CABLES

- 4 Dropper
- 5 Connection cables





Copper alloys

In recent years, La Farga has developed cutting-edge technology in copper alloys, which has allowed us to supply projects of different sizes worldwide.

CuAg

Silver is used as an alloying element to increase the base material's resistance to annealing, which makes to achieve better thermal stability of products that make up the catenary without sacrificing mechanical or electrical properties, and thus improving their durability.

Mechanical and electrical properties of contact wire

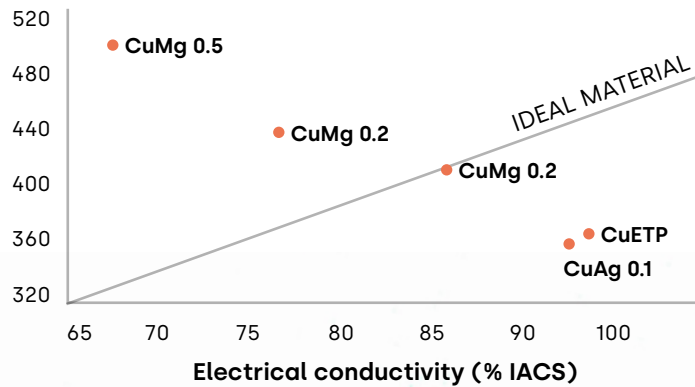

CuSn & CuMg

Tin and magnesium are used as an alloying element as they have a very high strength that allows suspension stresses to be applied sufficient to provide higher wave propagation speeds in the catenary. These alloys are needed on high performance railway lines, especially on high speed lines.

Contact wire annealing resistance

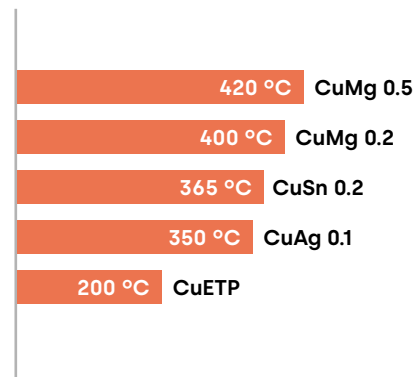







Conductors for railway electrification / Solutions / **Contact wire**

CONTACT WIRE

Range of products available for brands



CONTACT WIRE

Grooved contact wire is part of the catenary electrification system, designed for contact lines.

Furthermore, this wire has grooves that give it unique characteristics and advantages over conventional wires. The grooves allow for a more secure and stable connection.

La Farga supplies contact wire made of Copper (Cu), Copper Silver (CuAg), Copper Tin (CuSn) and Copper Magnesium (CuMg). The alloys offer superior properties by combining high tensile strength, high conductivity, increased thermal and wear resistance.

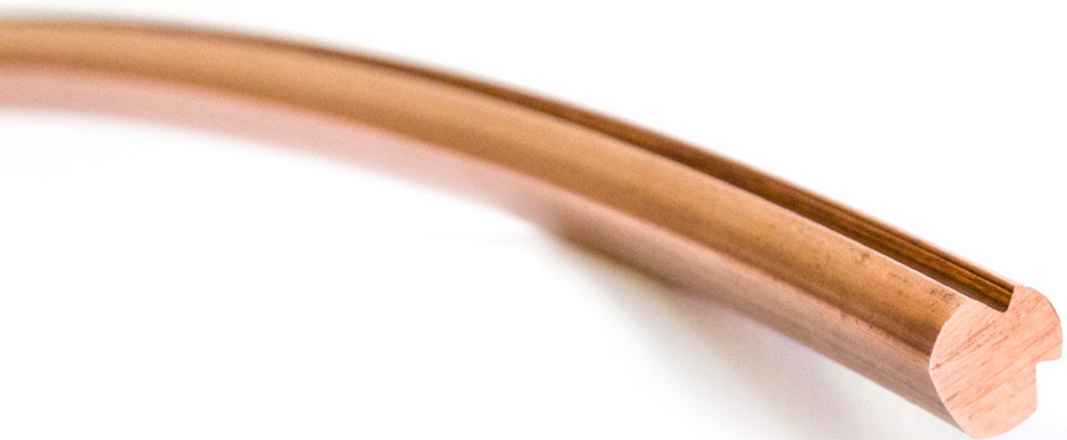

1 Contact wire



Technical specifications

Standard:

ASTM B-9 | ASTM B47 | EN 50149 | JIS E2101 | UIC 870 and according to customer specifications

Range:

- Cu-ETP (CW004A)
- CuAg 0.1 (CW013A)
- CuSn 0.2 (CW129C)
- CuMg 0.2 / 0.5 (CW127C) / (CW128C)

Sections:

- Circular: 80, 100, 107, 120, 150 mm²
- Oval: 100, 107, 120, 150 mm²

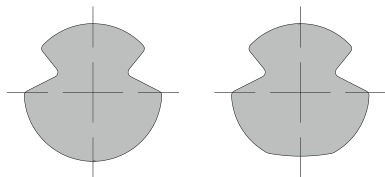

Identification grooves:

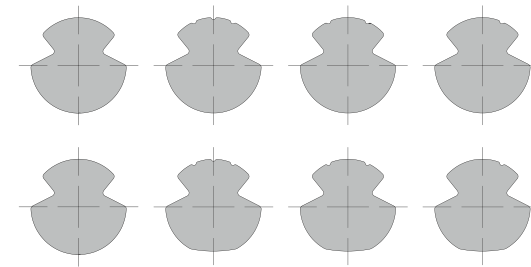

Cu-ETP no grooves CuMg 3 grooves CuAg 2 grooves CuSn 1 groove

Attachment grooves:

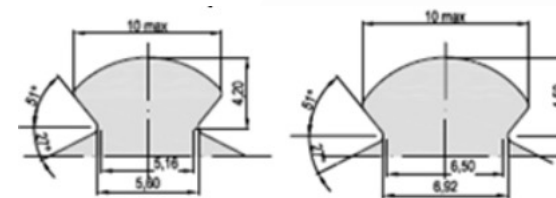

Type A groove

Type B groove



Technical characteristics in accordance with standard EN 50149: 2012

Cu-ETP

Cross section (mm ²)	Nominal Diameter / Height (mm)			Nominal mass (kg/km)	Electrical resistance (Ω/km)	Tensile strength (N/mm ²)	Breaking load (kN)	Current carrying capacity (A)*			Elongation (%)
	Profile BC	Profile AC	Profile BF					Profile BC	Profile AC	Profile BF	
80	-	10.62	-	712	0.229	375	29.1	-	459	-	3 - 8
100	11.71	11.96	11.04	889	0.183	375	36.4	527	530	519	3 - 8
107	12.15	12.40	11.23	952	0.171	360	37.4	550	553	539	3 - 8
120	12.91	13.13	12.27	1067	0.153	360	41.9	591	594	583	3 - 8
150	14.42	14.69	13.42	1334	0.122	360	52.4	681	685	669	3 - 8

* Calculation based on IEEE 738-2006 method according $W_s = 1\text{m/s}$, $R_s = 1000\text{ W/m}^2$, $T_a = 35^\circ\text{C}$, $T_c =$ depending on the alloy according to UNE-EN 50119 (80°C for Cu).

CuAg 0.1

Cross section (mm ²)	Nominal Diameter / Height (mm)			Nominal mass (kg/km)	Electrical resistance (Ω/km)	Tensile strength (N/mm ²)	Breaking load (kN)	Current carrying capacity (A)*			Elongation (%)
	Profile BC	Profile AC	Profile BF					Profile BC	Profile AC	Profile BF	
80	-	10.62	-	712	0.229	375	29.1	-	543	-	3 - 8
100	11.71	11.96	11.04	889	0.183	375	36.4	624	628	614	3 - 8
107	12.15	12.40	11.23	952	0.171	360	37.4	652	656	638	3 - 8
120	12.91	13.13	12.27	1067	0.153	360	41.9	701	704	691	3 - 8
150	14.42	14.69	13.42	1334	0.122	360	52.4	809	813	793	3 - 8

* Calculation based on IEEE 738-2006 method according $W_s = 1\text{m/s}$, $R_s = 1000\text{ W/m}^2$, $T_a = 35^\circ\text{C}$, $T_c =$ depending on the alloy according to UNE-EN 50119 (100°C for CuAg).



CuSn 0.2

Cross section (mm ²)	Nominal Diameter / Height (mm)			Nominal mass (kg/km)	Electrical resistance (Ω/km)	Tensile strength (N/mm ²)	Breaking load (kN)	Current carrying capacity (A)*			Elongation (%)
	Profile BC	Profile AC	Profile BF					Profile BC	Profile AC	Profile BF	
80	-	10.62	-	714	0.309	460	35.7	-	477	-	2 - 8
100	11.71	11.96	11.04	892	0.247	450	43.7	584	551	539	2 - 8
107	12.15	12.40	11.23	955	0.231	430	44.6	572	575	560	2 - 8
120	12.91	13.13	12.27	1071	0.206	420	48.9	616	619	607	2 - 8
150	14.42	14.69	13.42	1338	0.165	420	61.1	709	713	695	2 - 8

* Calculation based on IEEE 738-2006 method according $W_s = 1\text{m/s}$, $R_s = 1000\text{ W/m}^2$, $T_a = 35^\circ\text{C}$, $T_c =$ depending on the alloy according to UNE-EN 50119 (100°C for CuSn).

CuMg 0.5

Cross section (mm ²)	Nominal Diameter / Height (mm)			Nominal mass (kg/km)	Electrical resistance (Ω/km)	Tensile strength (N/mm ²)	Breaking load (kN)	Current carrying capacity (A)*			Elongation (%)
	Profile BC	Profile AC	Profile BF					Profile BC	Profile AC	Profile BF	
80	-	10.62	-	712	0.385	520	40.4	-	434	-	3 - 10
100	11.71	11.96	11.04	889	0.286	510	49.5	517	520	509	3 - 10
107	12.15	12.40	11.23	952	0.268	500	51.9	540	543	528	3 - 10
120	12.91	13.13	12.27	1067	0.239	490	57.0	581	584	573	3 - 10
150	14.42	14.69	13.42	1334	0.191	470	68.4	670	673	657	3 - 10

* Calculation based on IEEE 738-2006 method according $W_s = 1\text{m/s}$, $R_s = 1000\text{ W/m}^2$, $T_a = 35^\circ\text{C}$, $T_c =$ depending on the alloy according to UNE-EN 50119 (100°C for CuMg).



Packaging

1400 mm wooden reel

DIMENSIONS (mm)										
	A	B	C	D	E	F	G	H	I	J
1400	67	620	960	1400	750	82	65	518	250	250

For Cu-ETP & CuAg contact wire
Maximum weight: 2400 kg/reel

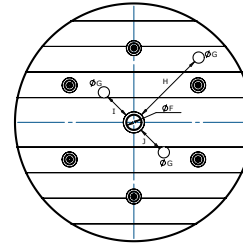
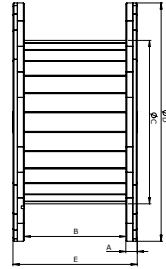

1800 mm wooden reel

DIMENSIONS (mm)									
	A	B	C	D	E	F	G	H	I
1800	70	560	1500	1800	700	82	70	800	600

For CuMg & CuSn contact wire
Maximum weight: 2500 kg/reel

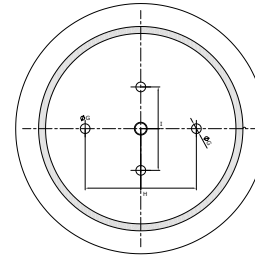
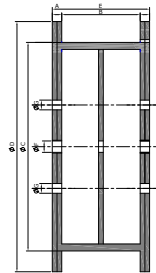

1650 mm metal reel

DIMENSIONS (mm)									
	A	B	C	D	E	F	G	H	I
1650	50	630	970	1650	750	82	60	225	17

For Cu-ETP contact wire and all its alloys
Maximum weight: 3000 kg/reel

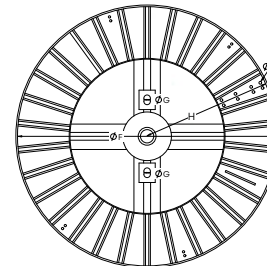
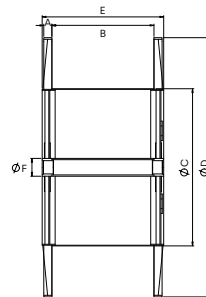

On being requested by the client, reinforced reels can be offered that make it possible to increase the capacity of the reels. Consequently, La Farga could also design and produce wooden or metallic drums with different dimensions.

The wooden reels are phytosanitary and come with staves and a banding.

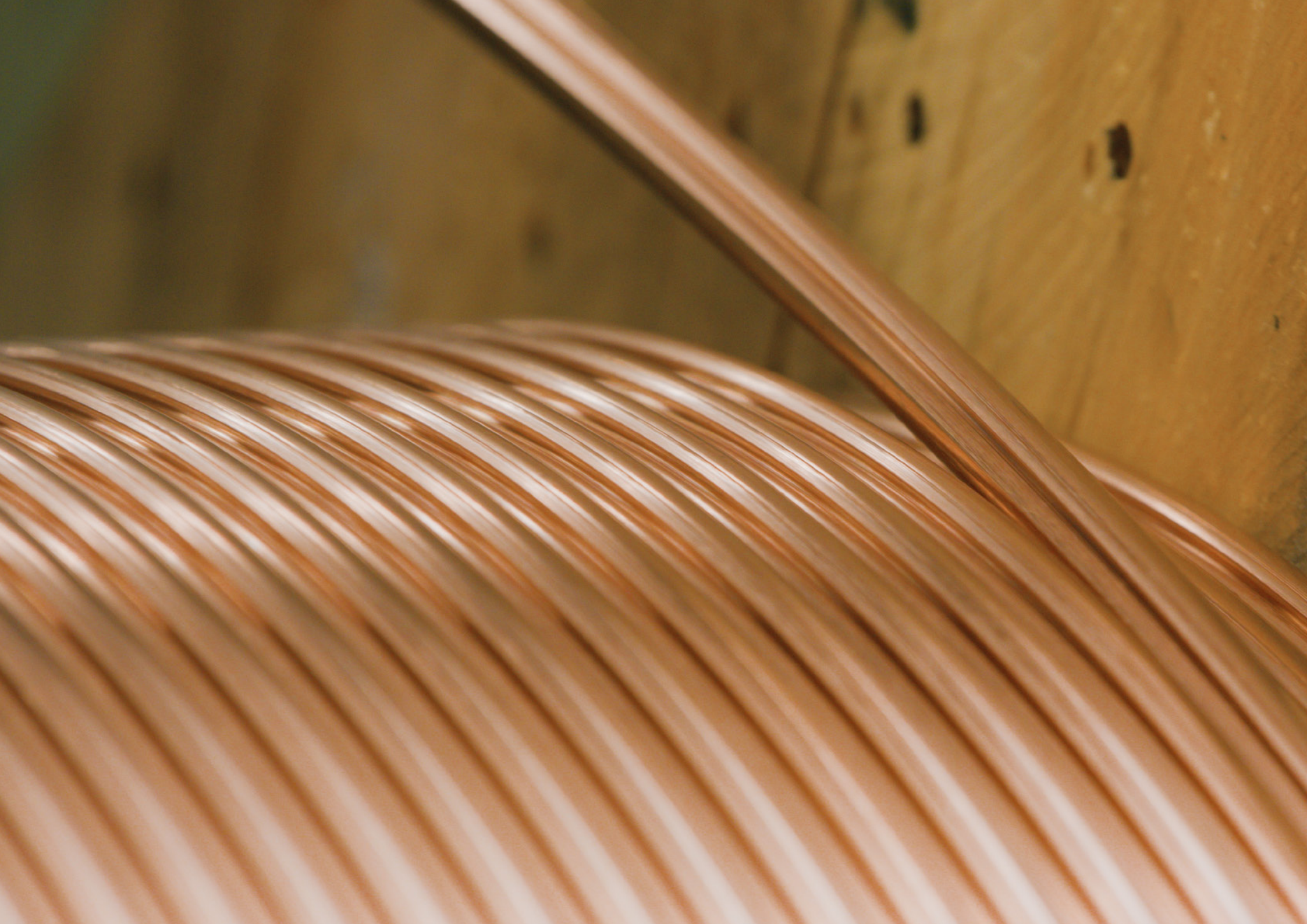





Conductors for railway electrification / Solutions / **Rigid cables**

RIGID CABLES

Range of products available for brands

La Farga



RAIL

Genius
by La Farga



RAIL

326

RIGID CABLES

The rigid cables of copper and its class 2 alloys support the weight of the system, consisting of the contact wire and the droppers, and provide the power supply for the system. They are used in connecting wires, supporting wires and feeder wires for the catenary of conventional and high-speed trains. These are used for:

- Messenger wire
- Feeder
- Connection cables

RIGID CABLES

- 2 Messenger wire
- 3 Feeder
- 5 Connection cables



Technical specifications

Standard:

DIN 4820-1 | DIN 48201-2 | NF C34-110-3 | NF C34-110-2 | ADIF ET 03.364.158.0 | ADIF ET 03.364.159.8 and according to customer specifications

Range:

- Cu-ETP (CW004A)
- CuMg 0.2 / 0.5 (CW127C) / (CW128C)

Cross-sections:

- Connecting cable: cross-sections from 50 to 100 mm².
- Messenger cables: cross-sections from 70 to 300 mm².
- Feeder cable: cross-sections up to 500 mm²

Technical characteristics

Rigid Cu cables in accordance with standard DIN 48201-3

Denomination	Cross section (mm ²)	Composition (units x mm)	Nominal diameter (mm)	Nominal mass (kg/km)	Breaking load (kN)	Current carrying capacity (A)*
10	10.02	7 x 1.35	4.1	90	4.02	117
16	15.89	7 x 1.70	5.1	143	6.37	155
25	24.25	7 x 2.10	6.3	218	9.72	203
35	34.36	7 x 2.50	7.5	310	13.77	252
50	49.48	7 x 3.00	9.0	446	19.84	317
50	48.35	19 x 1.80	6.0	437	19.38	313
70	65.81	19 x 2.10	10.5	596	26.38	379
95	93.27	19 x 2.50	12.5	845	37.39	472
120	116.99	19 x 2.80	14.0	1060	46.90	545
150	147.11	37 x 2.25	15.8	1337	58.98	629
185	181.62	37 x 2.50	17.5	1649	72.81	718
240	242.54	61 x 2.25	20.3	2209	97.23	861
300	299.43	61 x 2.50	22.5	2725	120.04	983
400	400.14	61 x 2.89	26.0	3640	160.42	1180
500	499.83	61 x 3.23	29.1	4545	200.38	1358

* Calculation based on IEEE 738-2006 method according $W_s = 1\text{m/s}$, $R_s = 1000\text{ W/m}^2$, $T_a = 35^\circ\text{C}$, $T_c =$ depending on the alloy according to UNE-EN 50119 (80°C for Cu).

Rigid Cu cables in accordance with ADIF ET03.364.158.0

Denomination	Cross section (mm ²)	Composition (units x mm)	Nominal diameter (mm)	Nominal mass (kg/km)	Breaking load (kN)	Current carrying capacity (A)*
50	50.0	19 x 1.83	9.15	455.4	1915	320
95	94.8	19 x 2.52	12.60	863.5	3427	478
150	147.1	37 x 2.25	15.75	1344.5	5450	631
153	153.0	37 x 2.30	16.10	1398.3	5695	647
185	184.5	37 x 2.52	17.64	1686.5	6526	728
225	224.6	37 x 2.78	19.46	2052.5	7942	822
240	236.0	37 x 2.85	19.95	2157.1	8347	848
300	304.2	61 x 2.52	22.68	2791.3	10392	996

* Calculation based on IEEE 738-2006 method according $W_s = 1\text{m/s}$, $R_s = 1000\text{ W/m}^2$, $T_a = 35^\circ\text{C}$, $T_c =$ depending on the alloy according to UNE-EN 50119 (80°C for Cu).

Rigid Cu cables in accordance with standard NF C32-110-3

Denomination	Cross section (mm ²)	Composition (units x mm)	Nominal diameter (mm)	Nominal mass (kg/km)	Electrical resistance (Ω/km)	Breaking load (kN)	Current carrying capacity (A)*
5.5	5.5	7 x 1.00	3.0	482	3.34	231	79
10.8	10.8	7 x 1.40	4.2	942	1.70	434	121
12.4	12.4	7 x 1.54	4.5	108	1.47	499	132
14.1	14.1	7 x 1.60	4.8	123	1.30	552	143
17.8	17.8	7 x 1.80	5.4	156	1.03	699	166
22	22	7 x 2.00	6.0	193	0.83	862	190
24.2	24.2	7 x 2.10	6.3	212	0.76	924	201
25.2	25.2	7 x 2.14	6.4	221	0.73	960	206
27.6	27.6	7 x 2.24	6.7	242	0.67	1052	217
34.4	34.4	7 x 2.50	7.5	301	0.53	1310	251
29.2	29.2	19 x 1.40	7.0	258	0.63	1130	227
38	38.2	19 x 1.60	8.0	337	0.486	1436	267
48	48.3	19 x 1.80	9.0	426	0.384	1817	309
60	59.7	19 x 2.00	10.0	526	0.311	2244	353
75	74.9	19 x 2.24	11.2	660	0.248	2736	407
93	93.3	19 x 2.50	12.5	822	0.199	3408	468
100	100.88	19 x 2.60	13.0	-	-	-	-
116	116.2	37 x 2.00	14.0	1028	0.161	4274	536
146	145.8	37 x 2.24	15.7	1290	0.128	5212	619
182	181.6	37 x 2.50	17.5	1606	0.103	6493	710
200	199.5	37 x 2.62	18.3	1764	0.0935	6722	753
228	227.8	37 x 2.80	19.6	2015	0.0819	7677	820
262	261.5	37 x 3.00	21.0	3213	0.0713	8813	894
288	288.3	37 x 3.15	22.0	2550	0.0647	9452	950
240	240.4	61 x 2.24	20.2	2130	0.0779	8307	847
299	299.4	61 x 2.50	22.5	2653	0.0625	10347	973
376	375.6	61 x 2.80	25.2	3328	0.0498	12226	1122
522	521.7	61 x 3.30	29.7	4622	0.0359	16519	1380
631	631.3	61 x 3.63	32.7	5593	0.0297	19376	1556

* Calculation based on IEEE 738-2006 method according $W_s = 1\text{m/s}$, $R_s = 1000\text{ W/m}^2$, $T_a = 35^\circ\text{C}$, $T_c =$ depending on the alloy according to UNE-EN 50119 (80°C for Cu).



Technical characteristics

Alloys

Bzll rigid cables in accordance with standard DIN 48201-2 (ADIF ET 03.364.159.8)

Denomination	Cross section (mm ²)	Composition (units x mm)	Nominal diameter (mm)	Nominal mass (kg/km)	Electrical resistance (Ω/km)	Breaking load (kN)	Current carrying capacity (A)*
10	10.02	7 x 1.35	4.1	90	2.803	5.88	115
16	15.89	7 x 1.70	5.1	143	1.768	9.33	153
25	24.25	7 x 2.10	6.3	218	1.158	14.24	200
35	34.36	7 x 2.50	7.5	310	0.817	20.17	249
50	49.48	7 x 3.00	9.0	446	0.568	28.58	314
50	48.35	19 x 1.80	6.0	437	0.584	28.39	309
70	65.81	19 x 2.10	10.5	596	0.429	38.64	376
95	93.27	19 x 2.50	12.5	845	0.303	54.76	469
120	116.99	19 x 2.80	14.0	1060	0.241	67.57	542
150	147.11	37 x 2.25	15.8	1337	0.192	86.37	628
185	181.62	37 x 2.50	17.5	1649	0.156	106.63	716
240	242.54	61 x 2.25	20.3	2209	0.117	142.40	861
300	299.43	61 x 2.50	22.5	2725	0.0947	175.80	985
400	400.14	61 x 2.89	26.0	3640	0.0755	231.12	1148
500	499.83	61 x 3.23	29.1	4545	0.0567	288.70	1367

* Calculation based on IEEE 738-2006 method according $W_s = 1\text{m/s}$, $R_s = 1000\text{ W/m}^2$, $T_a = 35^\circ\text{C}$, $T_c =$ depending on the alloy according to UNE-EN 50119 (100°C for Bzll).

Bz rigid cables in accordance with standard NF C34-110-2

Conductivity (%IACS)	Denomination	Cross section (mm ²)	Composition (units x mm)	Nominal diameter (mm)	Nominal mass (kg/km)	Electrical resistance (Ω/km)	Breaking load (kN)	Current carrying capacity (A)*
72	12 B	12.37	7 x 0.65	5	110	2.12	727	139
72	22	21.99	7 x 2.00	6.0	196	1.120	1301	201
72	34	33.58	19 x 1.50	7.5	303	0.744	14.24	261
72	48	48.35	19 x 1.80	9.0	434	0.518	2935	328
72	93	93.27	19 x 2.50	12.5	446	0.268	5358	499
72	116	116.24	37 x 2.00	14.0	1050	0.216	6850	573
72	148	148.07	19 x 3.15	15.8	1330	0.169	8028	669
72	182	181.61	37 x 2.50	17.5	1646	0.138	10400	761
60	22	21.99	7 x 2.00	6.0	196	1.350	1397	183
60	35	35.16	37 x 1.10	7.7	317	0.857	2385	245
60	48	48.35	37 x 2.50	9.0	434	0.620	3097	300
60	65	65.38	37 x 1.50	10.5	590	0.462	4323	362
60	93	94.15	37 x 1.80	12.6	850	0.320	6042	457
60	116	116.24	37 x 2.00	14.0	1050	0.26	7344	522
60	182	181.62	37 x 2.50	17.5	1646	0.167	10650	692
37	116	116.24	37 x 2.00	14.0	1050	0.451	8398	396

* Calculation based on IEEE 738-2006 method according $W_s = 1\text{m/s}$, $R_s = 1000\text{ W/m}^2$, $T_a = 35^\circ\text{C}$, $T_c =$ depending on the alloy according to UNE-EN 50119 (100°C for Bz).

Packaging

1250 mm wooden reel

	DIMENSIONS (mm)									
	A	B	C	D	E	F	G	H	I	J
1250	67	620	630	1250	750	82	65	65	160	160

Maximum weight: 2000 kg/reel

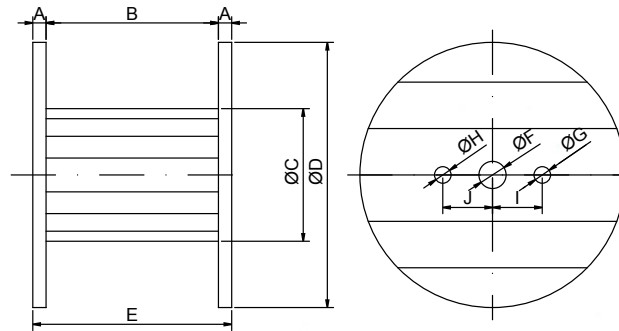

1650 mm metal reel

	DIMENSIONS (mm)								
	A	B	C	D	E	F	G	H	I
1650	50	630	970	1650	750	82	60	225	17

Maximum weight: 3000 kg/reel

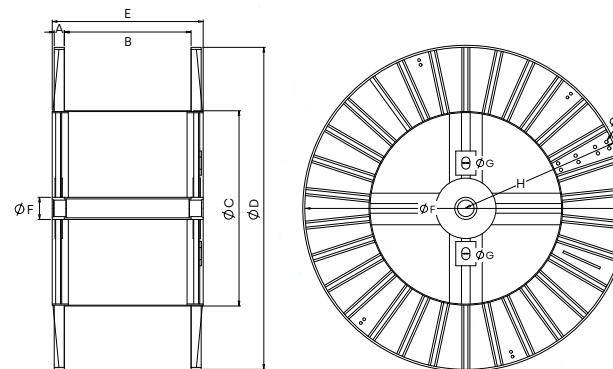

*On being requested by the client, reinforced reels can be offered that make it possible to increase the capacity of the reels. Consequently, La Farga could also design and produce wooden or metallic drums with different dimensions.
The wooden reels are phytosanitary and come with staves and a banding.*



○ Conductors for railway electrification / Solutions / **Flexible cables**

FLEXIBLE CABLES

Range of products available for brands

La Farga  RAIL

Genius  RAIL
by La Farga

FLEXIBLE CABLES

Flexible cables of copper and its alloys of class 5 and 6 are used as connecting cables.

FLEXIBLE CABLES

5 Connection cables

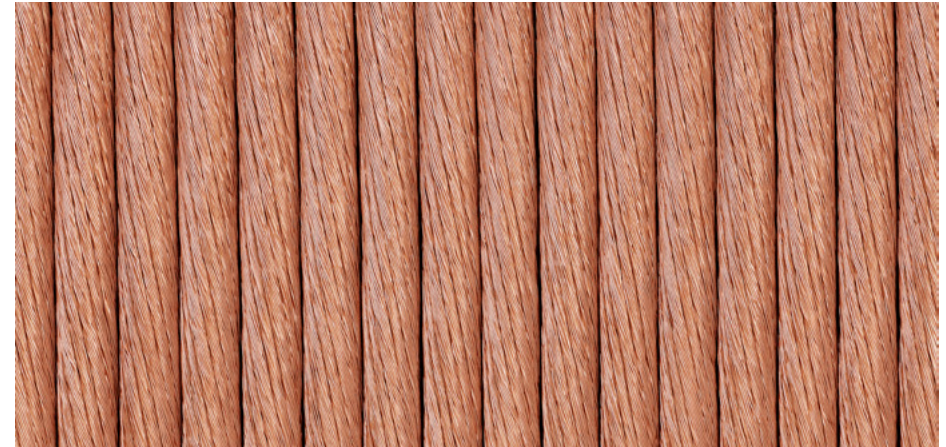
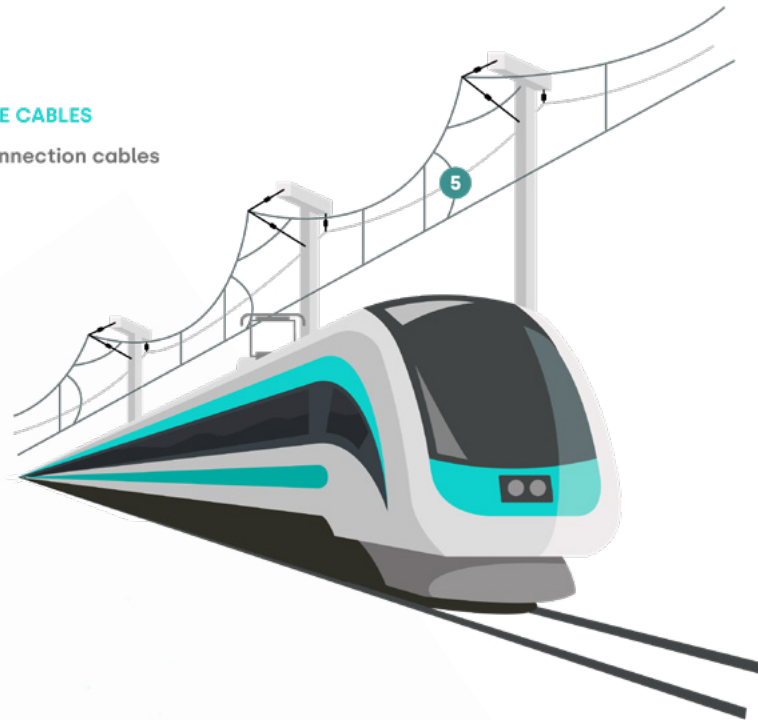

Technical specifications

Standard:

DIN 43138 | NF F 55-681 | ADIF ET 03.364.158.0 and according to customer specifications

Range:

- Cu-ETP (CW004A)
- CuMg 0.2 / 0.5 (CW127C) / (CW128C)

Cross-sections:

- Connection cables: cross-sections of 50, 95, 125, 150, 240 & 500 mm²



Technical characteristics

Flexible Cu cables in accordance with standard DIN 43138

Denomination (mm ²)	Cross section (mm ²)	Composition (units x mm)	Nominal diameter (mm)	Nominal mass (kg/km)	Electrical resistance (Ω/km)	Current carrying capacity (A)*
16	16.3	49 x 0.65	5.9	152	1.1654	159
25	26.1	133 x 0.50	7.5	246	0.7472	212
35	37.6	133 x 0.60	9.0	353	0.5080	269
50	51.2	133 x 0.70	10.5	482	0.3677	329
70	72.7	189 x 0.70	13.0	685	0.2587	414
95	99.7	259 x 0.70	14.7	935	0.1888	501
120	118.5	336 x 0.67	16.4	1120	0.1595	561
150	150.9	392 x 0.70	18.3	1420	0.1247	652
185	185.1	525 x 0.67	20.4	1745	0.0857	809
210	209.8	595 x 0.67	21.5	1980	0.0901	800
240	245.2	637 x 0.70	23.1	2320	0.0768	883
300	296.6	637 x 0.77	25.4	2800	0.0629	1000

* Calculation based on IEEE 738-2006 method according $W_s = 1\text{m/s}$, $R_s = 1000\text{ W/m}^2$, $T_a = 35^\circ\text{C}$, $T_c =$ depending on the alloy according to UNE-EN 50119 (80°C for Cu).



Flexible Cu cables in accordance with standard NF F55-681

Denomination (mm ²)	Cross section (mm ²)	Composition (units x units x mm)	Nominal diameter (mm)	Nominal mass (kg/km)	Electrical resistance (Ω/km)	Current carrying capacity (A)*
26	26	19 x 7 x 0.50	7.50	237	0.735	213
50	50	37 x 7 x 0.50	10.50	452	0.378	324
75	75	37 x 7 x 0.61	12.70	665	0.263	409
95	95	37 x 7 x 0.68	14.30	870	0.204	478
104.5	104.5	19 x 7 x 1.00	15.00	970	0.184	510
147	147	37 x 7 x 0.85	17.90	1323	0.131	633
164	164	37 x 7 x 0.90	18.35	1537	0.122	660

* Calculation based on IEEE 738-2006 method according $W_s = 1\text{m/s}$, $R_s = 1000\text{ W/m}^2$, $T_a = 35^\circ\text{C}$, $T_c =$ depending on the alloy according to UNE-EN 50119 (80°C for Cu).

Flexible Cu cables in accordance with ADIF ET 03.364.158.0

Denomination (mm ²)	Cross section (mm ²)	Composition (units x units x mm)	Nominal diameter (mm)	Nominal mass (kg/km)	Electrical resistance (Ω/km)	Current carrying capacity (A)*
95	89.54	19 x 24 x 0.50	13.10	816	0.210	461
120	111.92	37 x 30 x 0.50	14.80	1020	0.165	537
150	141.76	37 x 38 x 0.50	16.40	1292	0.134	612
240	232.47	37 x 32 x 0.50	20.50	2125	0.084	819

* Calculation based on IEEE 738-2006 method according $W_s = 1\text{m/s}$, $R_s = 1000\text{ W/m}^2$, $T_a = 35^\circ\text{C}$, $T_c =$ depending on the alloy according to UNE-EN 50119 (80°C for Cu).

Packaging

1250 mm wooden reel

	DIMENSIONS (mm)									
	A	B	C	D	E	F	G	H	I	J
1250	67	620	630	1250	750	82	65	65	160	160

Maximum weight: 2000 kg/reel

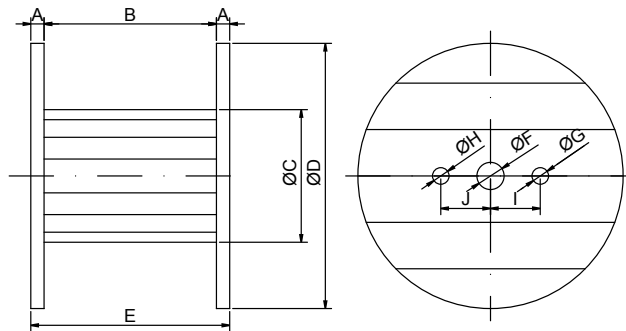

*On being requested by the client, reinforced reels can be offered that make it possible to increase the capacity of the reels. Consequently, La Farga could also design and produce wooden or metallic drums with different dimensions.
The wooden reels are phytosanitary and come with staves and a banding.*



 Conductors for railway electrification / Solutions / **Dropper**

DROPPER

Range of products available for brands



DROPPER

The dropper supports the contact wire and maintains the distance between the contact wire and the horizontal plane of the locomotive.

La Farga produces two types of droppers:

- Equipotential dropper
- Dropper rod

FLEXIBLE CABLES

4 Dropper

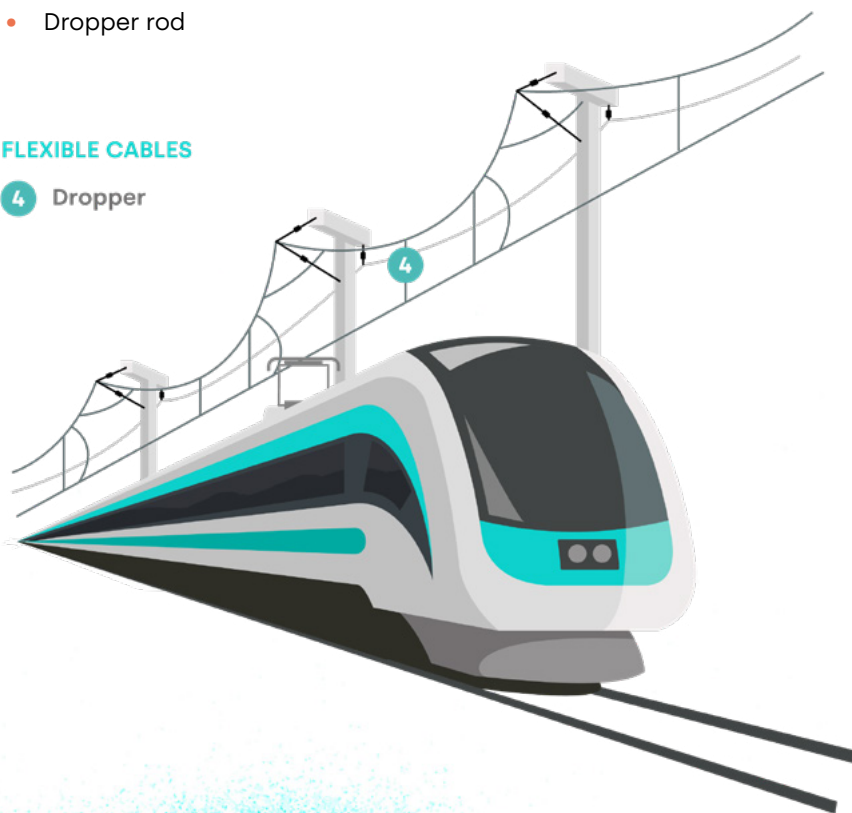

Technical specifications

Standard:

DIN 48138 | NF C34-110-2 | ADIF ET 03.364.158.0 and according to customer specifications.

Range:

- Cu-ETP (CW004A)
- CuSn 0.2 (CW129C)
- CuMg 0.2 / 0.5 (CW127C) / (CW128C)

Cross-sections:

Suspension wire from 3 mm Ø to 6 mm Ø

- Cu-ETP: 25 mm² sections
- CuSn: 12 mm² sections
- CuMg: 10, 16 & 25 mm² sections

Technical characteristics

Bzll dropper in accordance with standard DIN 43138

Conductivity (% IACS)	Denomination (mm ²)	Cross section (mm ²)	Composition (units x mm)	Nominal diameter (mm)	Nominal mass (kg/km)	Braking load (N)
62	10	9.6	49 x 0.50	4.6	89	116
62	16	16.3	49 x 0.65	5.9	152	195
62	16	16.3	84 x 0.50	6.2	152	116
62	25	26.1	133 x 0.50	7.5	346	116
62	35	37.6	133 x 0.60	9.0	353	167

* Calculation based on IEEE 738-2006 method according $W_s = 1\text{m/s}$, $R_s = 1000\text{ W/m}^2$, $T_a = 35^\circ\text{C}$, $T_c =$ depending on the alloy according to UNE-EN 50119 (100°C for Bzll).

Bz dropper in accordance with standard NF C34-110-2

Conductivity (% IACS)	Denomination (mm ²)	Cross section (mm ²)	Composition (units x mm)	Nominal diameter (mm)	Nominal mass (kg/km)	Electrical resistance (Ω/km)	Braking load (N)
80	12 B	11.94	7 x 0.65 + 42 x 0.54	5.0	110	2.05	728
72	12 B	11.94	7 x 0.65 + 42 x 0.54	5.0	110	2.12	727

* Calculation based on IEEE 738-2006 method according $W_s = 1\text{m/s}$, $R_s = 1000\text{ W/m}^2$, $T_a = 35^\circ\text{C}$, $T_c =$ depending on the alloy according to UNE-EN 50119 (100°C for Bz).

Cu dropper in accordance with ADIF ET 03.364.158.0

Denomination (mm ²)	Cross section (mm ²)	Composition (units x mm)	Nominal diameter (mm)	Nominal mass (kg/km)	Electrical resistance (Ω/km)	Braking load (kg)
25	25	8 x 64 x 0.25	7.7	234	0.738	500

* Calculation based on IEEE 738-2006 method according $W_s = 1\text{m/s}$, $R_s = 1000\text{ W/m}^2$, $T_a = 35^\circ\text{C}$, $T_c =$ depending on the alloy according to UNE-EN 50119 (80°C for Cu).



Packaging

800 mm wooden reel

		DIMENSIONS (mm)									
	A	B	C	D	E	F	G	H	I	J	
800	66	400	400	800	532	82	40	40	100	150	

Maximum weight: 500 kg/reel

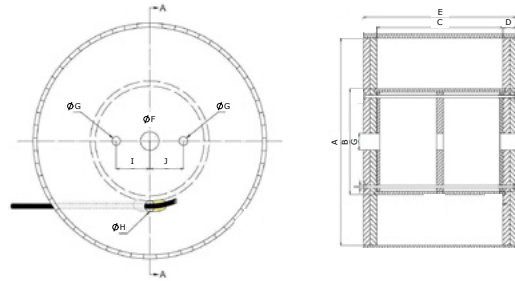

1250 mm wooden reel

		DIMENSIONS (mm)									
	A	B	C	D	E	F	G	H	I	J	
1250	67	620	630	1250	750	82	65	65	160	160	

Maximum weight: 2000 kg/reel

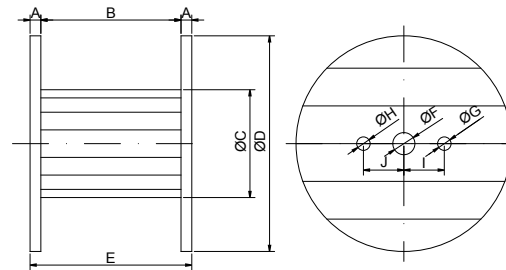

On being requested by the client, reinforced reels can be offered that make it possible to increase the capacity of the reels. Consequently, La Farga could also design and produce wooden or metallic drums with different dimensions.

The wooden reels are phytosanitary and come with staves and a banding.

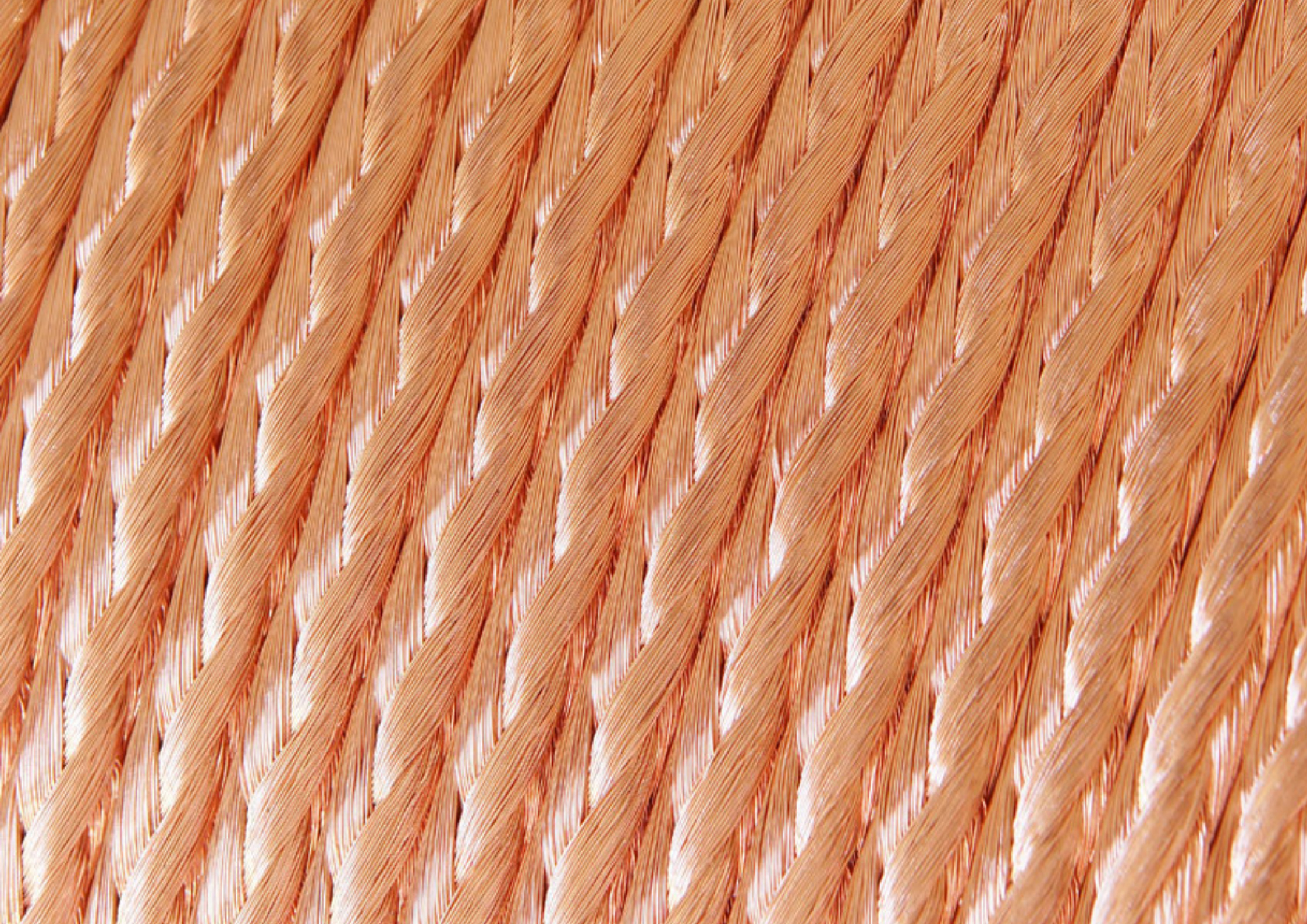







LA FARGA yourcoppersolutions, S.A.

Colònia Lacambra S/N

08508 / Les Masies de Voltregà (Barcelona) / Spain

lafarga@lafarga.es / www.lafarga.es /  Follow us